

## Cross-Hardtail

- A = Seat Tube Length
- B = Top Tube Length (Actual)
- B\* = Top Tube Length (Horizontal)
- C = Chainstay Length
- D = Head Tube Height
- E = Head Tube Angle
- F = Seat Tube Angle
- G = Seatpost diameter
- H = Bottom Bracket Drop
- K = Wheel Base
- L = Standover Height

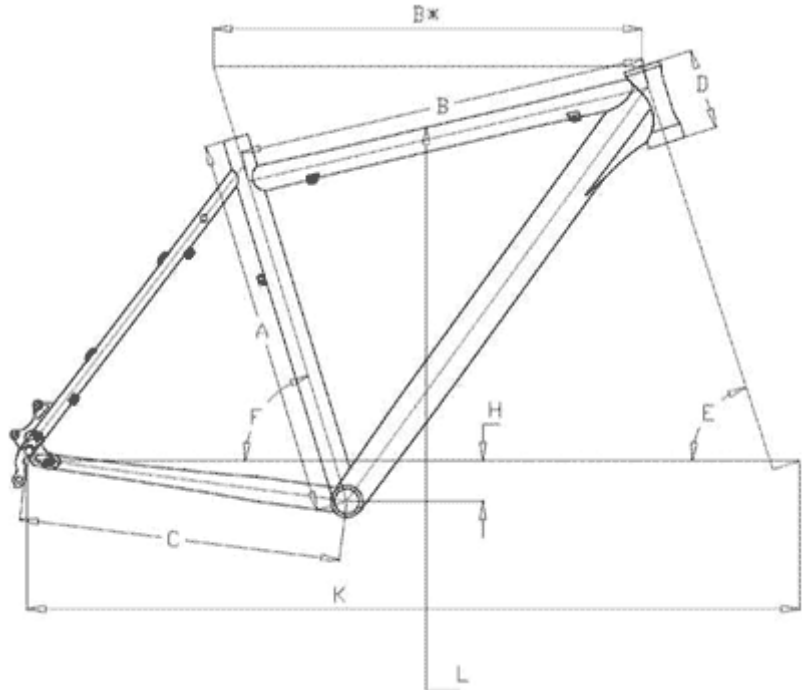

### “Cross Allround Hardtail Geometry”

Beluga Disc / Beluga / Beluga N-8 / Transmit / Rephlex

RH	A	B	B*	C	D	E	F	G	H	K	L
46	460	552	577	440	100	72°	73°	27.2	60	1047	773
52	520	550	580	440	115	72°	73°	27.2	55	1052	816
56	560	566	590	440	135	72°	73°	27.2	55	1063	846
61	605	582	600	440	160	72°	73.5°	27.2	55	1079	882

all dimensions in mm