

Asphalt

- A = Seat Tube Length
- B = Top Tube Length (Actual)
- B* = Top Tube Length (Horizontal)
- C = Chainstay Length
- D = Head Tube Height
- E = Head Tube Angle
- F = Seat Tube Angle
- G = Seatpost diameter
- H = Bottom Bracket Drop
- K = Wheel Base
- L = Standover Height

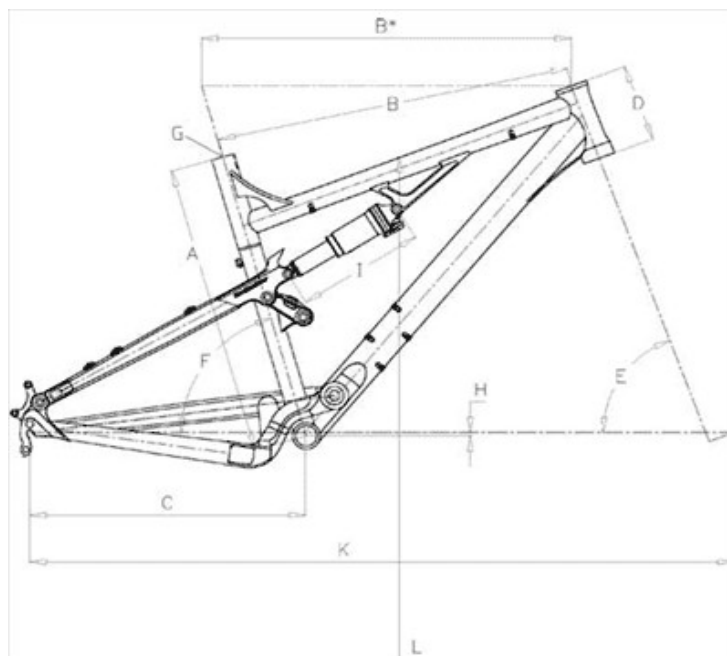

Road

Dolce

RH	A	B	B*	C	D	E	F	G	H	K	L
47*	470	525	520	405	115	71°	74°	31.6	75	970	742
51	510	524	535	405	120	72.5°	74°	31.6	72	973	767
54	540	539	550	405	130	73°	74°	31.6	70	981	786
56	560	551	560	405	155	73.5°	73.5°	31.6	70	991	808
58	580	566	575	407	180	73.5°	73°	31.6	70	1005	834
61	610	580	590	410	200	74°	73°	31.6	68	1019	837

all dimensions in mm