

### Contrail

- A = Seat Tube Length
- B = Top Tube Length (Actual)
- B\* = Top Tube Length (Horizontal)
- C = Chainstay Length
- D = Head Tube Height
- E = Head Tube Angle
- F = Seat Tube Angle
- G = Seatpost diameter
- H = Bottom Bracket Drop
- I = Eye to Eye
- K = Wheel Base
- L = Standover Height

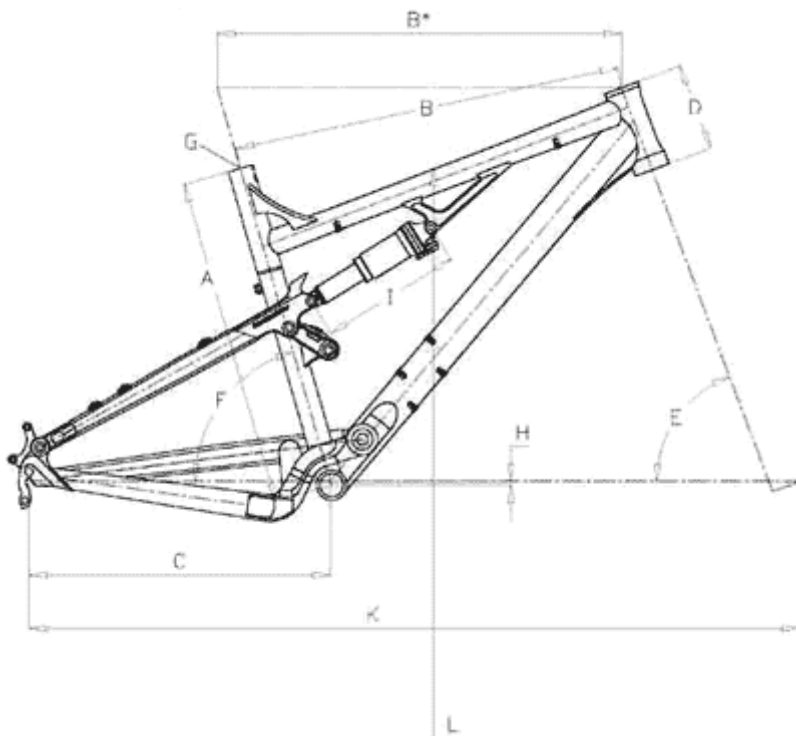

### Enduro

RH	A	B	B*	C	D	E	F	G	H	I	K	L
<b>S</b>	430	549	563	438	115	67.5°	71.5°	30.9	15	200	1097	789
<b>M</b>	470	560	583	438	125	68°	71.5°	30.9	15	200	1112	812
<b>L</b>	500	577	603	438	130	68°	71.5°	30.9	15	200	1132	826
<b>XL</b>	530	589	618	438	140	68.5°	71.5°	30.9	15	200	1142	846

*all dimensions in mm*