

## Asphalt

- A = Seat Tube Length
- B = Top Tube Length (Actual)
- B\* = Top Tube Length (Horizontal)
- C = Chainstay Length
- D = Head Tube Height
- E = Head Tube Angle
- F = Seat Tube Angle
- G = Seatpost diameter
- H = Bottom Bracket Drop
- K = Wheel Base
- L = Standover Height

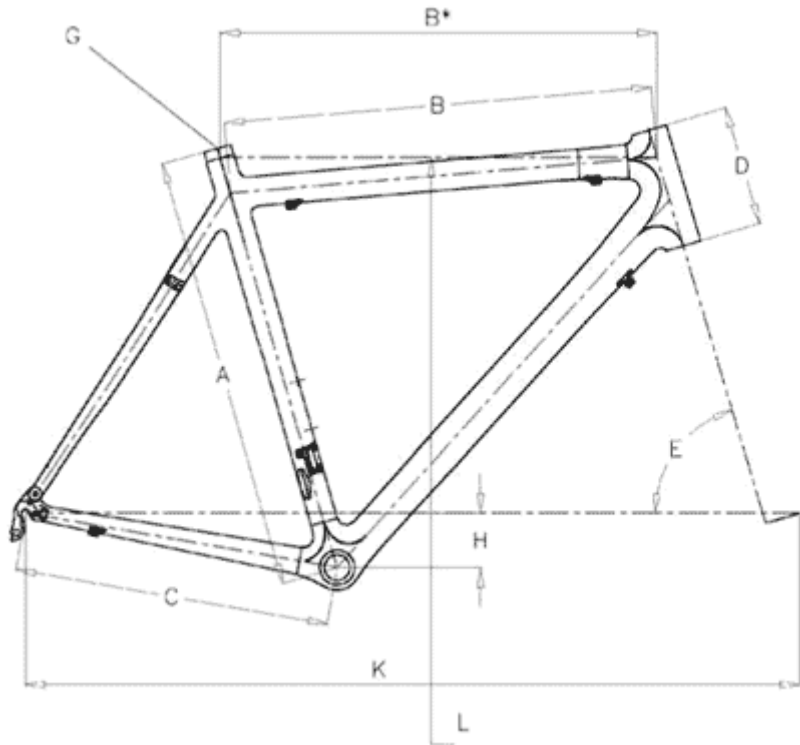

## "Speed Geometry"

Prime Speed / Beluga Speed

RH	A	B	B*	C	D	E	F	G	H	K	L
<b>46</b>	465	552	575	430	140	73°	74°	27.2	60	1040	761
<b>52</b>	520	557	580	430	160	73°	74°	27.2	55	1046	809
<b>56</b>	560	567	585	430	175	73°	74°	27.2	55	1053	836
<b>61</b>	610	578	590	430	190	73°	74°	27.2	55	1058	869

all dimensions in mm