

Cross-Hardtail

- A = Seat Tube Length
- B = Top Tube Length (Actual)
- B* = Top Tube Length (Horizontal)
- C = Chainstay Length
- D = Head Tube Height
- E = Head Tube Angle
- F = Seat Tube Angle
- G = Seatpost diameter
- H = Bottom Bracket Drop
- K = Wheel Base
- L = Standover Height

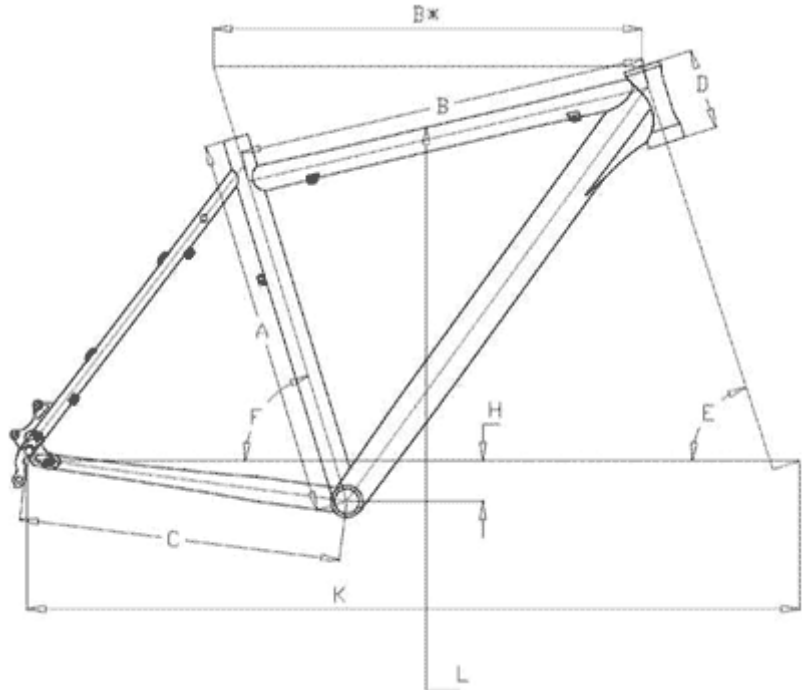

“Cross Sport Hardtail Geometry”

Men's Prime Tec Disc / Prime Tec / Crosstec Disc

RH	A	B	B*	C	D	E	F	G	H	K	L
46	460	557	580	440	95	72°	73°	31.6	60	1051	769
52	520	562	585	440	110	72°	73°	31.6	55	1056	812
56	560	573	595	440	130	72°	73°	31.6	55	1067	842
61	600	588	605	440	155	72°	73.5°	31.6	55	1083	875

all dimensions in mm